

Weld Booths

**Welding Safety
and Health** 

Quick Specs

Industrial Applications

Heavy equipment
manufacturing
Fabrication
Schools and training
facilities

Configurations

Modular configuration depending on design
layout — panels can be used as sides or backs

Material

16-gauge steel with 1.5 in. square tube
structure with black textured powder coat

Dimensions

Widths/depths: Available in
4, 5 and 6 ft. panel widths —
mix and match
Overall weld booth height: 78 in.
Panel height from ground: 27.5 in.

Panel Weight

4 ft.: 63 lb.
5 ft.: 75 lb.
6 ft.: 88 lb.

Configurable weld booths with single-panel design for maximum modularity and customizability.

Engineered to seamlessly integrate into a variety of training and other welding environments. Weld booth panels are available in 4, 5, and 6-foot widths to be used as back or side walls.

NEW!



Order exactly what you need to fit your layout:

- Modular panels (sold individually)
- Hardware kit (one per booth) contains the following: weld curtain, curtain rod and hardware

Note: Simple nut-and bolt assembly is required.

Weld booth benefits

- **Single-panel modular design** to fit any space with a variety of configurations
- **Black textured powder coat** for sleek look and long-lasting durability
- **Walls are 27.5 inches from the ground** to provide safety and accessibility
- **California fire marshal approved, amber see-through weld curtains**
- **Multiple different arm mounting locations**
- **Floor anchoring feet** (floor anchoring is optional and installation is the responsibility of customer)

Contact FiltairQuotes@millerwelds.com for more information.



Booths are warranted for one year, parts and labor.



Miller Electric Mfg. LLC

An ITW Welding Company
1635 West Spencer Street
P.O. Box 1079
Appleton, WI 54912-1079 USA

Equipment Sales US and Canada

Phone: 866-931-9730
FAX: 800-637-2315
International Phone: 920-735-4554
International FAX: 920-735-4125

MillerWelds.com



Weld Booth Configurations (Examples)

Single booth



- 1 back wall (choose width)
- 2 side walls (choose depth)
- 3 total panels (dimensions can be different)

Two connected booths (shared back wall)

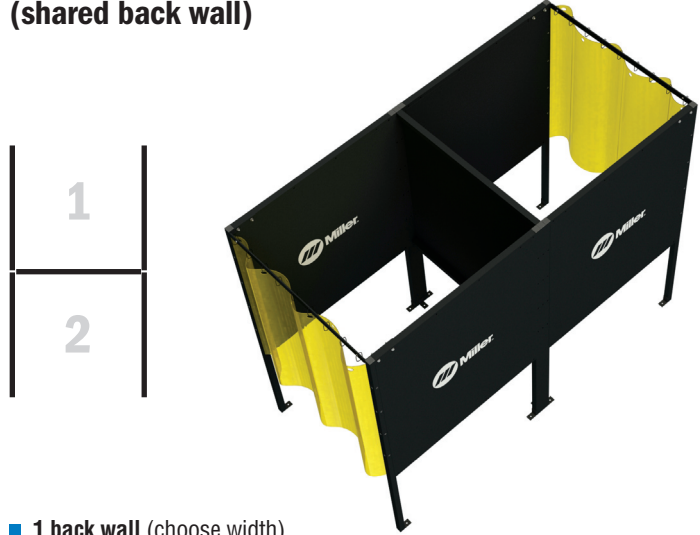

- 1 back wall (choose width)
- 4 side walls (choose depth)
- 5 total panels (dimensions can be different)

Two connected booths (shared side wall)



- 2 back walls (choose width)
- 3 side walls (choose depth)
- 5 total panels (dimensions can be different)

Even number of connected booths (shared side and back walls)



- 2 back walls (choose width)
- 6 side walls (choose depth)
- 8 total panels (dimensions can be different)

Panel Corner Assembly Options

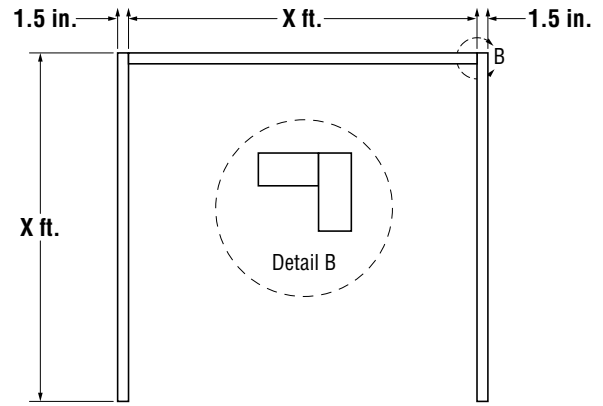
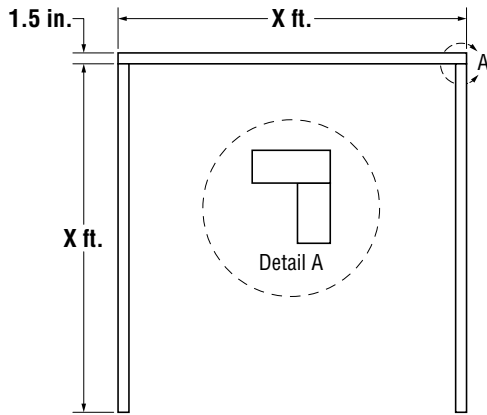

Genuine Miller® Accessories

Workstations

ArcStation™ 60WX 951000107

Workstation is 35 x 58 x 29 inches (H x W x D) and is compatible with 5-foot and larger weld booths.

ArcStation™ 30FX 300837

Workstation is 35 x 29 x 29 inches (H x W x D) and is compatible with 4-foot and larger weld booths.



5-foot booth shown with ArcStation 60WX workstation



4-foot booth shown with ArcStation 30FX workstation

FILTAIR® Extraction Arms

Easy-to-operate, pre-assembled extraction arms and mounting equipment. See literature AY/3.7 for more information.

- **Telescoping arms** are designed to fit small booth spaces used in training centers and educational booths. Telescopes from 3 to 4.5 feet with a wide range of motion to cover all positions.
- **Standard arms** are designed to cover larger spaces and are available in 7-, 10-, and 12-foot versions. External brackets and adjustments allow air to pass through with less resistance giving you stronger cfm (airflow).
- **Arm mounting bracket and ducting kit** includes a supporting bracket and collar for connecting an extraction arm to ductwork.



Telescoping arm



Standard arm

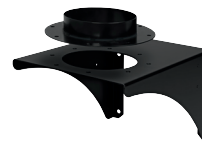

Arm mounting bracket and ducting kit



4-foot booth shown with FILTAIR telescoping arm

Ordering Information



Weld booth panels sold individually



Modular design for optimal customizability for your space

Weld Booth	Stock No.	Description	Qty.	Price
4 ft. Panel	295140	Single panel — can be used as back or side wall		
5 ft. Panel	295126	Single panel — can be used as back or side wall		
6 ft. Panel	296015	Single panel — can be used as back or side wall		
Hardware Kit	295581	Includes hardware, curtain rod, weld curtain — order 1 hardware kit per booth		
Accessories				
Workstations	951000107 300837	ArcStation™ 60WX (exclusive ArcStation table for use with weld booths) ArcStation™ 30FX		
FILTAIR® Extraction Arms		See literature AY/3.7		

Date:

Total Quoted Price:

Call us toll-free at 866-931-9730 or email us at filtair@millerwelds.com for more information and request-for-quotes on custom-engineered layouts to fit your needs.

Distributed by:

